

# Parking

Parking Revenue Systems &  
Entry Solutions



tuned to you

Contents?

# ESPAS 10 line

**k** Entry/exit station for parking systems for collective use, able to operate in "stand-alone" mode. The device controls the entry or exit route and can be connected to electromechanical barriers.

**k** Frontal "tip" opening for convenient inspection, without hindering the access point and possibly the wall mounting. Durable and reliable over time thanks to a chassis with monobloc structure.

**k** Operation with token or coin acceptor with fixed or programmable values and alphanumeric display for showing the amount to be inserted.

**k** Stainless steel sheet body with protective treatment and polyester paint.



**StandAlone**

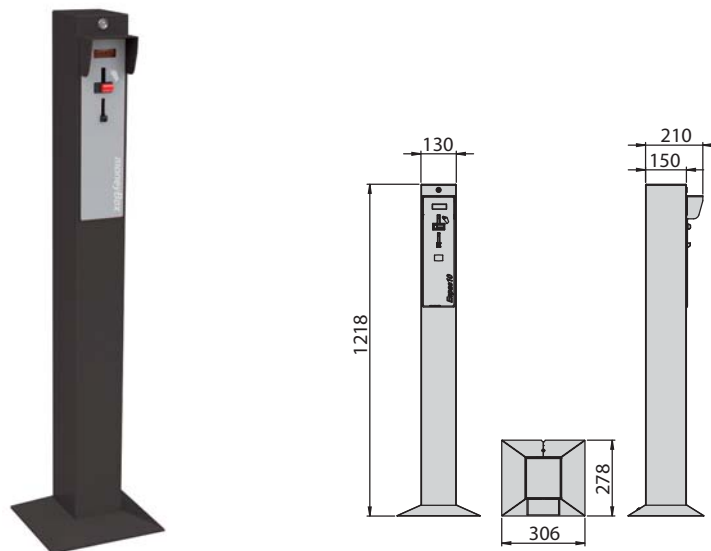

ESPAS 10  
ENTRY/EXIT

## CONFIGURATIONS

B PG A 210 R1	€1.00 coin acceptor
B PG A 210 R2	€2.00 coin acceptor
B PG A 210 R3	Coin acceptor: 10, 20, 50 cents and €1.00 or €2.00
B PG A 210 R4	Fixed tariff grooved token acceptor
B PD A 210 R3	Token dispenser, payment in banknotes/coins
B PD A 210 R4	Token dispenser, payment in banknotes/coins, change giver

## COMPLEMENTARY ACCESSORIES

B PA A 202 R1	Payment amount programming software for acceptor B PGA 210 R3
B PA A 201 R1	Installation base for dispenser B PDA 210 R3
B PA A 201 R2	Installation base for dispenser B PDA 210 R4

# ESPAS 20 line

k "Stand Alone" system for collective and commercial car park solutions. Interface between the different devices of the system and calculation of tariff through the issue of a ticket fan folder with type 2D barcode and reading via optical module with integrated motion detection function.

Easy to inspect and manage, facilitated by the front opening of the ESPAS 20 systems.

k LCD alphanumeric display, voice synthesis and backlit vandal-proof buttons.

k RFID proximity reader for operator cards and customer pass with memory for up to 100 cards.

k Electronic card with display and integrated joystick for rapid programming.



**StandAlone**

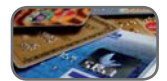

**CC for  
UK-FR-IT-AUS**



ESPAS 20T  
MANUAL CASH



ESPAS 20  
ENTRY/EXIT



ESPAS 20  
AUTOMATIC PAY STATION

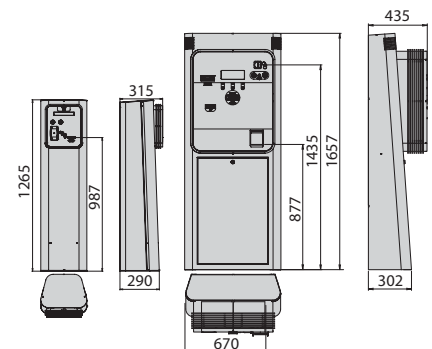

## CONFIGURATIONS

B PI A 210 R1	Stand alone entry column, BARCODE ticket, ISO CARD pass
B PI A 210 R2	Stand alone entry column, BARCODE ticket, ISO CARD pass, digital intercom
B PI A 210 R3	Stand alone entry column, BARCODE ticket, ISO CARD pass, barcode permit
B PI A 210 R4	Stand alone entry column, BARCODE ticket, pass ISOCARD, barcode permit, digital intercom
B PU A 210 R1	Stand alone exit column, BARCODE ticket, ISO CARD pass, barcode permit
B PU A 210 R2	Stand alone exit column, BARCODE ticket, ISO CARD pass, barcode permit, digital intercom
B PC A 210 R1	Automatic pay station for stand-alone systems
B PC A 210 R2	Automatic pay station for stand-alone systems, credit card
B PC A 210 R3	Manual pay station/table validator for stand-alone systems

## COMPLEMENTARY ACCESSORIES

B PA A 203 R1	Space counter system for stand alone systems
B PA A 205 R1	Bft 4000 p ticket box
B PA A 205 R2	Bft 4000 p customised ticket box
B PA A 204 R1	Traffic light panel

# ESPAS 30 line

**k** System wired on RS485 serial network for commercial and professional applications. The entry/exit stations have a graphic display for indicating the operations underway, voice synthesis for audio instructions and integrated optical module (motion detection) for reading and management of 2D barcode ticket fan folders.

Easy to inspect and manage, facilitated by the front opening of the ESPAS 30 systems.

**k** Graphic display, voice synthesis for user help messages and backlit vandal-proof buttons.

**k** Expanding modular system for future addition of accessories and complementary solutions including: internal and external addressing, available spaces signposting, UHF tag reading, etc.



CableSystem



CC for  
UK-FR-IT-AUS



ESPAS 30T  
MANUAL CASH



ESPAS 30  
ENTRY/EXIT



ESPAS 30  
AUTOMATIC PAY STATION

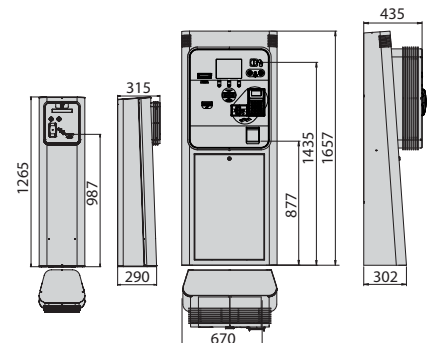

## CONFIGURATIONS

B PI A 220 R1	Entry column, BARCODE ticket, ISO CARD permit
B PI A 220 R2	Entry column, BARCODE ticket, ISO CARD permit, digital intercom
B PI A 220 R3	Entry column, BARCODE ticket, ISO CARD permit, barcode permit
B PI A 220 R4	Entry column, BARCODE ticket, ISO CARD permit, barcode permit, digital intercom
B PI A 220 R5	Entry column, BARCODE ticket, ISO CARD permit, barcode permit, long range UHF (B PTA) permit, digital intercom
B PU A 220 R1	Exit column, BARCODE ticket, ISO CARD permit, barcode permit
B PU A 220 R2	Exit column, BARCODE ticket, ISO CARD permit, barcode permit, digital intercom
B PU A 220 R3	Exit column, BARCODE ticket, ISO CARD permit, barcode permit, long range UHF (B PTA) permit, digital intercom
B PC A 220 R1	Automatic pay station for wired systems
B PC A 220 R2	Automatic pay station for wired systems, credit card
B PC A 220 R3	Manual pay station/table validator for wired systems
B PS A 220 R1	System server for wired systems with management software

## COMPLEMENTARY ACCESSORIES

B PA A 205 R1	Bft 4000 p ticket box
B PA A 205 R2	Bft 4000 p customised ticket box
B PA A 204 R1	Traffic light panel
B PT A 201 R1	Integrated antenna for B PTA tag reading
B PT A 202 R1	Tag for B PTA system
B PT A 202 R2	Fixed non-removable tag for B PTA system

# Comparative table

	Espas 10	Espas 20	Espas 20 CC	Espas 30	Espas 30 CC
<b>COMMUNICATION BETWEEN DEVICES</b>					
Stand alone operation	x	x	x	-	-
RS485 communication protocol	-	-	-	x	x
<b>USER INTERFACE</b>					
Alphanumeric display on entry/exit station	-	x	x	x	x
Alphanumeric display on automatic pay station	-	x	x	-	-
Graphic display on automatic pay station	-	-	-	x	x
Multi-language voice synthesis	-	x	x	x	x
<b>SINGLE USER MANAGEMENT</b>					
Ticket with 2D barcode	-	x	x	x	x
Courtesy time management	-	x	x	x	x
Ticket on fanfold thermal paper	-	x	x	x	x
Linear tariff linked only to the time spent in the car park	x	-	-	-	-
<b>PERMIT USER MANAGEMENT</b>					
Operator pass on ISO125KHz card	-	x	x	x	x
Permits on ISO 125KHz card	-	-	-	x	x
Permits on barcode ticket	-	x	x	x	x
Antipassback function on entry/exit station	-	-	-	x	x
Time-slot permits on iso card	-	-	-	x	x
Prepaid decremental permits on iso card (time, amount, transits)	-	-	-	x	x
Permits on "free-hand" support	-	-	-	x	x
Short-term time-slot permits on ticket	-	x	x	x	x
Short-term prepaid decremental permits on ticket (time, amount, transits)	-	x	x	x	x
Short-term permits on daily ticket	-	x	x	x	x
<b>AUTOMATIC PAY STATION</b>					
Payment by credit card*	-	-	x	-	x
Coin payment up to 5 coins	-	x	x	x	x
Change given up to 5 coins	-	x	x	x	x
Change given up to 4 coins, high capacity	-	-	-	-	-
Banknote payment up to 4 banknotes	-	x	x	x	x
Change given, 1 banknote	-	x	x	x	x
Alphanumeric display	-	x	x	-	-
Graphic display	-	-	-	x	x
Automatic coin jam clearance	-	x	x	x	x
Lost ticket function	-	x	x	x	x
Payment data re-write on ticket function	-	x	x	-	-
Receipt request	-	x	x	x	x
Secondary coin box	-	x	x	x	x
Cash movement report	-	x	x	x	x
Programmable thermostat control system	-	x	x	x	x
Control unit on Industrial PC	-	-	-	x	x
<b>MANNED PAY STATION</b>					
Centralised management software	-	-	-	x	x
ISO card permit issue	-	-	-	x	x
System software management from remote station	-	-	-	x	x

<b>Legend</b>	
-	Not available
x	Supplied as standard
*	Credit card availability subject to service availability in country of installation

# Night & Day - Speed

New 230 Vac electromechanical barrier designed for intensive use complete with dedicated control unit CSB-SP for arms 1.7 ÷ 3m with an opening time of 0.8s.

It houses a three-phase ventilated motor coupled with a monolithic oil lubricated gearbox driven by an INVERTER, which guarantees excellent performance.

The barrier is supplied as standard with: a safety micro switch that disables the controls when the service door is open, a "Reverser" that reverses the direction of the arm if an obstacle is hit, preset electromechanical limit switches and black ABS cover for hand protection.



## TECHNICAL CHARACTERISTICS

	<b>NIGHT &amp; DAY-SPEED</b>
Supply voltage	230V ± 1 0% 50/60 Hz
Manual Release	Inside the structure
Control Unit	Built-in mod. CSB-SP
Duty Cycles	20,000 Manoeuvres
Opening Time	Regolable up to 2.2 sec
Safety at Impact	Reversing in closing
Boom Length	3m
Working Temperature	- 30° C + 60° C
Movement	With slow down limit
Protection Level	IP 65
Colour	Red RAL 3002 rough finish or colours on request

# Night & Day-3 and Night & Day-5

Enclosed in a simple and robust cabinet, this strong and reliable motor is tested up to 40,000 operations per day and is suitable for the toughest weather conditions. The exceptional build quality of this barrier makes it ideal for very high frequency Toll use. All this, together with an industry standard exterior coating and a rapid 1.7 second operating time makes the Night & Day 3 a market leader.

## NIGHT & DAY-5 (FOR MEDIUM - WIDE VEHICLES)

Ideally suited for medium - wide vehicles, this barrier will easily perform thousands of operations per day. The highly rated motor is extremely quiet and will exceed the technical specifications if required.

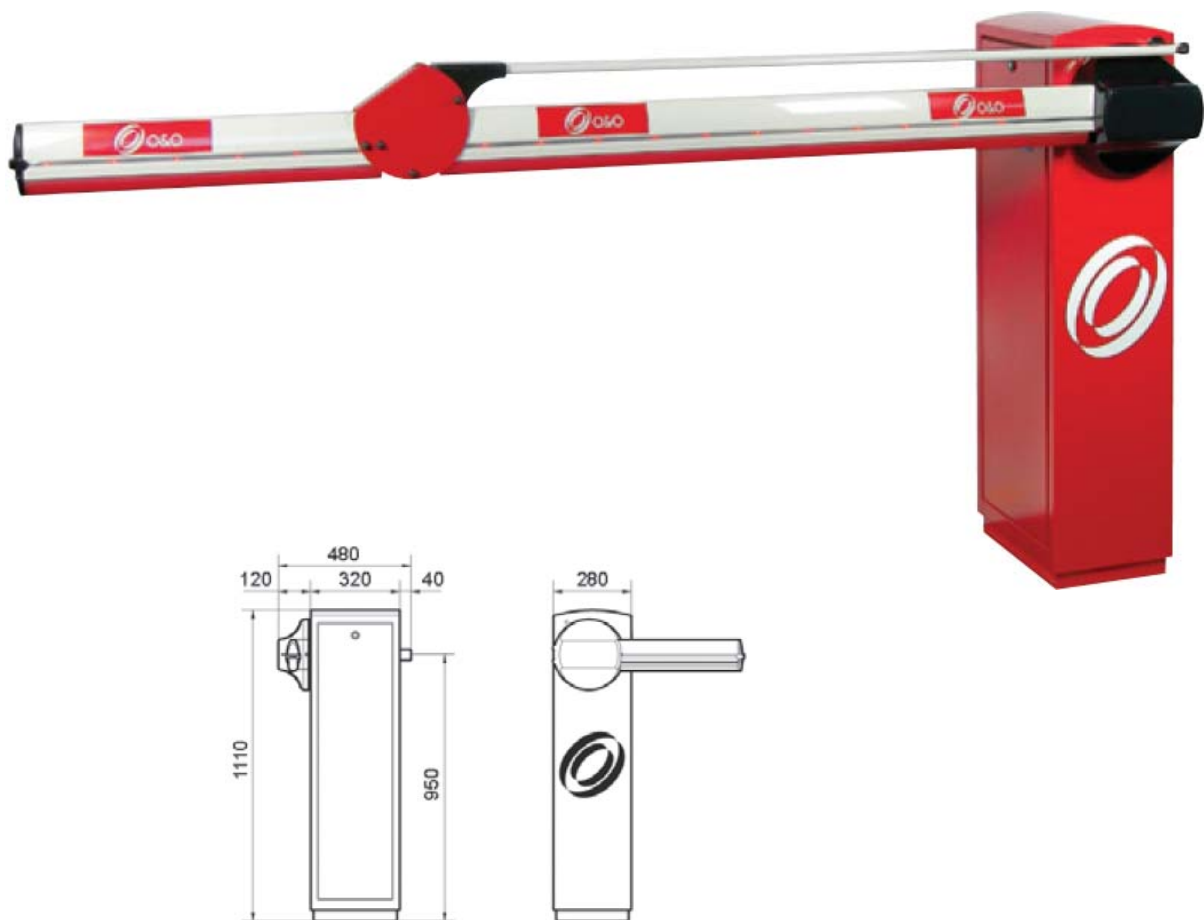

## TECHNICAL CHARACTERISTICS

	NIGHT & DAY-3	NIGHT & DAY-5
Supply voltage	230V ± 1 0% 50/60 Hz	230V ± 1 0% 50/60 Hz
Manual Release	Inside the structure	Inside the structure
Control Unit	Built-in mod. CSB-BR	Built-in mod. CSB-BR
Duty Cycles	10,000 Day manoeuvres	5,000 Day manoeuvres
Opening Time	1.7"	3.8"
Safety at Impact	Reversing in closing	Reversing in closing
Boom Length	3m	5m
Working Temperature	- 30° C + 60° C	- 30° C + 60° C
Movement	With slow down limit	With slow down limit
Protection Level	IP 65	IP 65
Colour	Red RAL 3002 rough finish or colours on request	Red RAL 3002 rough finish or colours on request



# Night & Day-DD3

To complete the barrier range to suit every need, we have developed the DD3 barrier. This model features automatic opening in case of power loss without the need for external assistance. This is particularly suited to sensitive sites where waiting for a manual override key in the event of power loss will waste vital time or is not practical.



## TECHNICAL CHARACTERISTICS

Supply voltage	230V $\pm$ 1 0% 50/60 Hz
Manual Release	Spontaneous
Control Unit	Built-in mod. ARX 246 dd3
Duty Cycles	10,000 Day manoeuvres
Opening Time	1.7"
Safety at Impact	Reversing in closing
Boom Length	3m
Working Temperature	- 30° C + 60° C
Movement	With slow down limit
Protection Level	IP 65
Colour	Red RAL 3002 rough finish or colours on request

# Night & Day-6 and Night & Day-8

## NIGHT & DAY-6 (FOR LARGE VEHICLES)

Night & Day-6 was born out of 40 years' experience in controlling access of large vehicles. With boom lengths of up to 6 metres and an opening time of 8 seconds, its simple construction and straight forward technology make this barrier an extremely reliable choice.

## NIGHT & DAY-8 (FOR LARGE VEHICLES/DUAL LANE TRAFFIC)

Night & Day-8 is the largest of our barriers, and uses the same mechanics as Night & Day-6 with specific developments which give the boom, of up to 8 metres, an automatic slow-down on closing which helps eliminate barrier bounce and oscillation.

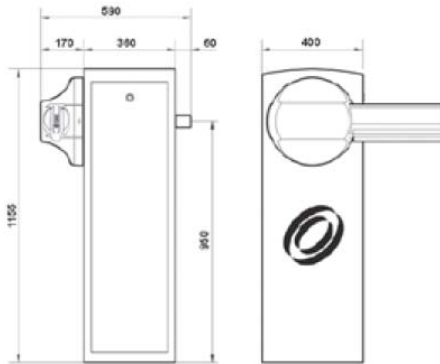

## TECHNICAL CHARACTERISTICS

	NIGHT & DAY-3	NIGHT & DAY-5
Supply voltage	230V ± 1 0% 50/60 Hz	230V ± 1 0% 50/60 Hz
Manual Release	Inside the structure	Inside the structure
Control Unit	Built-in mod. CSB-BR	Built-in mod. CSB-BR
Duty Cycles	2,000 Day manoeuvres	2,000 Day manoeuvres
Opening Time	8"	8"
Safety at Impact	Reversing in closing	Reversing in closing
Boom Length	6m	8m
Working Temperature	- 30° C + 60° C	- 30° C + 60° C
Movement	With slow down limit	With slow down limit
Protection Level	IP 65	IP 65
Colour	Red RAL 3002 rough finish or colours on request	Red RAL 3002 rough finish or colours on request

# Stopy Mbb

- k 230 V ac electromechanical bollard with internal oil-bath gear motor. Stopy-Mbb is the ideal solution for contexts of particular architectural and urban interest, with specially studied colours and a new design for the floor flange and light crown.
- k Designed to work in the most extreme conditions, with all metal parts treated with cataphoresis and the new EPDM seal integrated in the flange and led light crown, which with the bollard lowered, fits perfectly into the floor flange drastically reducing the entry of waste materials into the bollard housing, thanks to a special steel trap; it is completely independent from the rest of the machine allowing for pre-installation and future laying of the bollard.
- k PERSEO CBD control unit with menu programming on the display, automatic routine servicing warning, simultaneous management of up to 4 bollards, integrated receiver and integrated heating element.



STOPPY MBB  
STOPPY MBB INOX

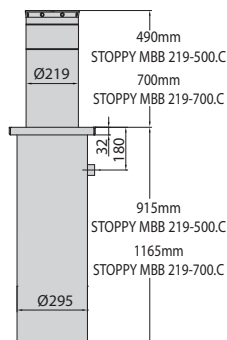

**PERSEO CBD dedicated control panel: manages up to 4 bollards in parallel, programming menu on the display, integrated heating element and incorporated receiver.**

**Main accessories: RME 1 BT 24V metal mass detector, one channel / RME 2 230V metal mass detector, two channels/ SPIRA 2x1 magnetic coil 2x1 m**

## TECHNICAL CHARACTERISTICS

	STOPPY MBB 500	STOPPY MBB 700
Supply voltage	230V ± 1 0% 50/60 Hz	230V ± 1 0% 50/60 Hz
Hand operated	Spontaneous	Spontaneous
External control unit	PERSEO CBD	PERSEO CBD
Work type	intensive 1,500 movements/day	intensive 1,500 movements/day
Rising time	6 seconds	9 seconds
Protection rating	IP 67	IP 67
Impact resistance	10,500 JOULES	10,500 JOULES
Break-in proof	150,000 JOULES	150,000 JOULES
Operating temperature	- 20° C + 60° C	- 20° C + 60° C
Movement	With slow down on opening and closing	With slow down on opening and closing

# Easy

Value for money and quality. These are the roots of the new EASY bollards. The result of a careful market survey looking into the assembly techniques and design details that led to the production of a simple bollard that responds to customer needs without neglecting the quality requirements that have always marked BFT products. All at a competitive price. EASY comes in two models: the first, EASY Ø115-500, has a Ø115 mm, 500 mm high rod. It has no light crown but is fitted with a rear-reflecting strip. The second, EASY Ø200-700, has a Ø200 mm, 700mm high rod, a light crown and a rear-reflecting strip.



EASY Ø115/500

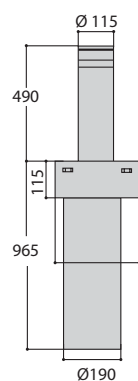

EASY Ø200/700

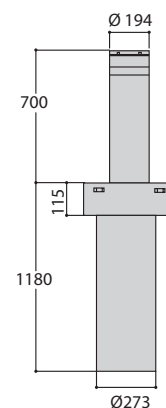

**PERSEO CBD dedicated control panel: manages up to 4 bollards in parallel, programming menu on the display, integrated heating element and incorporated receiver.**

**Main accessories: RME 1 BT 24V metal mass detector, one channel / RME 2 230V metal mass detector, two channels/ SPIRA 2x1 magnetic coil 2x1 m**

## TECHNICAL CHARACTERISTICS

	EASY Ø115/500	EASY Ø200/700
Supply voltage	230V ± 1 0% 50/60 Hz	230V ± 1 0% 50/60 Hz
Hand operated	Manual	Manual
External control unit	External mod. PERSEO CBD	External mod. PERSEO CBD
Work type	500 movements/day	500 movements/day
Rising time	7 seconds	9 seconds
Protection rating	IP 67	IP 67
Impact resistance	6,000 JOULES	6,000 JOULES
Break-in proof	60,000 JOULES	60,000 JOULES
Operating temperature	- 20° C + 60° C	- 20° C + 60° C
Movement	With slow down on opening and closing	With slow down on opening and closing

# Scudo G

k These gas-spring operated rising bollards were designed to offer road access control at competitive prices and with an extremely simple operation. They are operated using special keys now used throughout Europe in public places. They are lowered at the press of a foot and are automatically locked into place at the bottom. Given their size and similar appearance, they can be used in mixed installations to cover wide passages managed by both electric and gas operated bollards. The models are available with grey painted RAL 7015 rods, adhesive strip H:100 mm, only for 210 mm diameter models, and in stainless steel.



SCUDO-G Ø115/500  
SCUDO-G Ø115/500 INOX

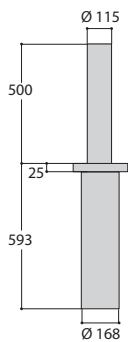

SCUDO-G Ø210/500  
SCUDO-G Ø210/500 INOX

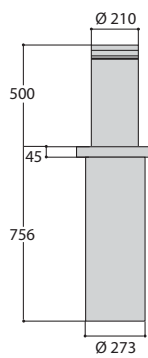

SCUDO-G Ø210/700  
SCUDO-G Ø210/700 INOX

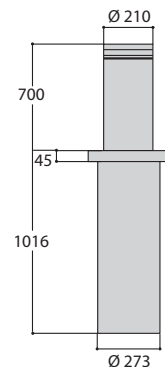

## TECHNICAL CHARACTERISTICS

	SCUDO-G Ø115-500	SCUDO-G Ø210-500	SCUDO-G Ø210-700
Rod size	Ø115 mm H: 500 mm	Ø220 mm H: 500 mm	Ø220 mm H:700 mm
Rod thickness	4 mm	6 mm	6 mm
Impact resistance	5,000 JOULES	10,000 JOULES	10,000 JOULES
Break-in proof	30,000 JOULES	60,000 JOULES	60,000 JOULES
Rod treatment	Cataphoresis	Cataphoresis	Cataphoresis
Rod movement	Internal gas spring	Internal gas spring	Internal gas spring
Lifting thrust	100 N	170 N	150 N
Surface finish	grey paint RAL 7015 + rear-reflecting film	grey paint RAL 7015 + rear-reflecting film	grey paint RAL 7015 + rear-reflecting film
Rod locking	with triangle key	with triangle key	with triangle key

# Scudo F

k Fixed bollards used for permanent closure of accesses, bolted to the ground, they block accesses and roads or offer protection for sensitive sites. These bollards can be integrated and combined with other bollards of similar shapes and sizes. They have a class-2 type approved highly reflecting adhesive strip.



SCUDO-F Ø220-500  
SCUDO-F Ø220-500 INOX

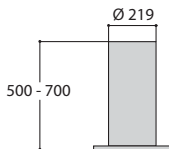

SCUDO-F Ø220-700  
SCUDO-F Ø220-700 INOX

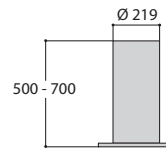

## TECHNICAL CHARACTERISTICS

	<b>SCUDO-F Ø220-500</b>	<b>SCUDO-F Ø220-700</b>
Rod size	Ø220 mm H: 500 mm	Ø220 mm H: 700 mm
Rod thickness	3 mm	3 mm
Rod treatment	Cataphoresis	Cataphoresis
Surface finish	powder painted RAL 7015 + rear-reflecting film H=100 mm	powder painted RAL 7015 + rear-reflecting film H=100 mm
Fixing flange	Ø 340 mm steel, 5 mm thick	Ø 340 mm steel, 5 mm thick
Bollard fixing	With 3 fixing screws	With 3 fixing screws

# Privee

“PRIVEE” automatic 24 V dc chain barrier for intensive use, for closing off access areas to residential and industrial sites and small private car parks with widths of up to 16 metres.

Highly robust, cathaphoresis treated and painted steel structure, the “PRIVEE” represents an excellent and safe solution for protecting public and private areas, with an “encoder” reverse motion system, and blends perfectly into any urban setting. Supplied as standard with armoured padlock and numbered key.



PRIVEE-ON

PRIVEE-OFF

CHAIN  
UP TO 10 or 16 m

(PRV - CHN 10)  
(PRV - CHN 16)

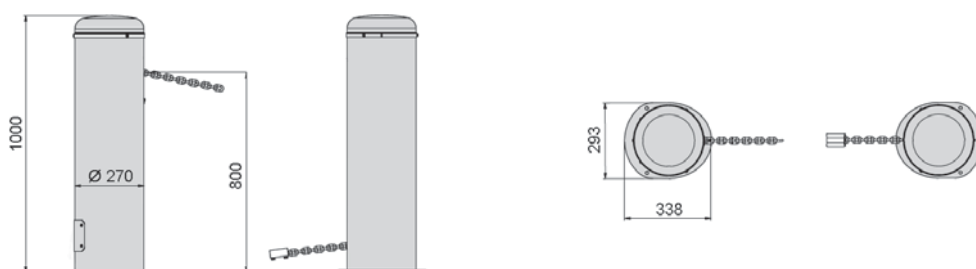

**LOG-BC incorporated control panel: integrated receiver 2048 codes and input/output status indicator LED**

**Main accessories: CHN DRIVE 2 floor guide for chain housing with drainage slits / CELLULA 130 pair of 24V self aligning photocells / RADIUS B LTA 24 flashing with integrated 24V antenna**

## TECHNICAL CHARACTERISTICS

	<b>PRIVEE</b>
Supply voltage	24V dc
Control unit	incorporated Mod. LOG-BC with integrated receiver
Chain	Ø 8 mm for 10 m openings / Ø 4.5 mm for openings up to 16 m
Safety	armoured padlock for anchoring chain fitted with numbered key
Work type	intensive use
Opening time	10 sec.
Opening width	up to 10 m (PRV-CHN 10) and up to 16 m (PRV-CHN 16)
Impact safety	“ENCODER” reverse motion when closing
Operating temperature	-20°C + 60°C

# Grizzly

Demonstrating the continuous research to improve our products and service, today O&O has expanded its range of automatic bollards to include hydraulic technology. Following in-depth studies conducted in collaboration with renowned research centres and various product tests, O&O presents the first models with the following features.



**LOG-BC incorporated control panel: integrated receiver 2048 codes and input/output status indicator LED**  
**Main accessories: CHN DRIVE 2 floor guide for chain housing with drainage slits / CELLULA 130 pair of 24V self aligning photocells / RADIUS B LTA 24 flashing with integrated 24V antenna**

## TECHNICAL CHARACTERISTICS

	<b>PRIVEE</b>
Supply voltage	230 Vac 50 Hz supply voltage
Control unit	
Chain	
Safety	
Work type	intensive use - 3,000 manoeuvres a day
Opening time	5 secs H:600mm and 6 secs H:800mm.
Opening width	
Impact safety	Safety valve that reverses the direction if an obstacle is detected
Operating temperature	-15°C + 60°C - -30°C + 60°C with "TERMON" integrated heating circuit



# Bft, tuned to you

With Bft, your job gets easier.

Because we don't just create "good" products, that work pretty well.

Our thinking is beyond the short-term.

We are conceiving, designing and creating high-tech solutions that are as advanced and effective as they are reliable and long-lasting.

Because we want to provide tools and services that truly are innovative, that will improve your performance and enhance your skills; and that will make your business easier, increasing its profitability.

Because our focus is on Quality with a capital Q.

We just won't settle for less.

**Bft Automation UK Ltd (North)**  
Unit 8E, Newby Road Industrial Est  
Hazel Grove, Stockport, Cheshire,  
SK7 5DA  
Tel: 0161 456 0456  
Fax: 0161 456 9090

[www.bft.co.uk](http://www.bft.co.uk)

**Bft Automation UK Ltd (South)**  
Unit B, Aerial Business Park  
Membury, Berkshire,  
RG17 7RZ  
Tel: 0800 32 88 198  
Fax: 0800 32 88 298

[www.bft.co.uk](http://www.bft.co.uk)

**Bft Ireland**  
Unit 1, Naas Rd Business Park  
Muirfield Drive  
Dublin 12  
Tel: 01 4564711  
Fax: 01 4508337

[www.bftautomation.ie](http://www.bftautomation.ie)